



Replacing Burner Switch Spring Series 150S/157S Manual Reset Models

Date 10/26/98

All work must be performed by qualified personnel trained in the proper application, installation, and maintenance of plumbing, steam, and electrical equipment and/or systems in accordance with all applicable codes and ordinances.

1. Units with red reset button on bottom of junction box are covered by this procedure.

Units with white reset plunger should be replaced with a new head.

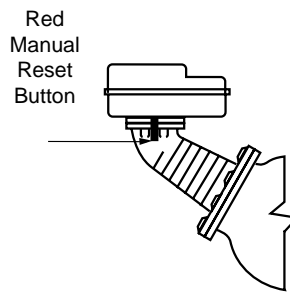

Replace Switch Spring
Follow Repair
Instructions Below

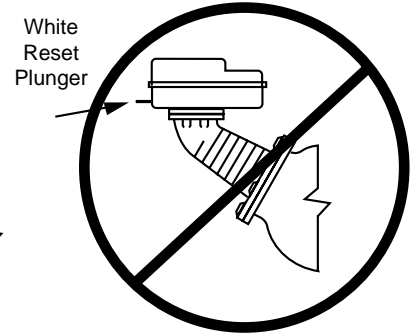

Cannot Field Repair
Requires Head Replacement

2. Reduce boiler pressure to zero psi.

Turn off power to burner switch and pump switch circuits.

Lower water level below casting mark on control body.

When control has cooled to a safe temperature, remove junction box cover.

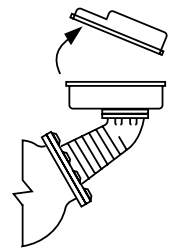
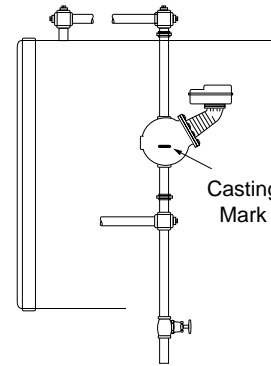
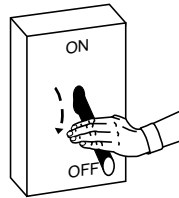

3. A standard prepackaged bag of five (5) replacement springs has been provided. **Only one spring is needed to repair unit**, extra springs have been provided in case of mishandling or loss during replacement.

A pair of needle nose pliers with serrated jaws is recommended to remove and replace springs. Pliers with small jaws will work better.



Old Spring



New Spring

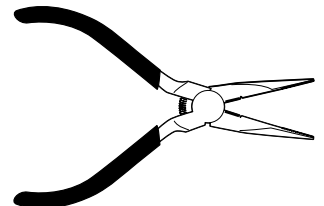

4. Locate burner switch which has three wires attached to terminals 4, 5 & 6, and red manual reset button.

Note: Pump switch does not have a spring and does not require service.

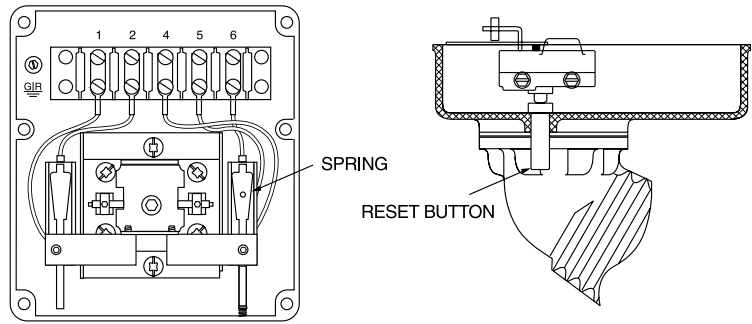

5. Insert pliers into switch behind spring and remove old spring.

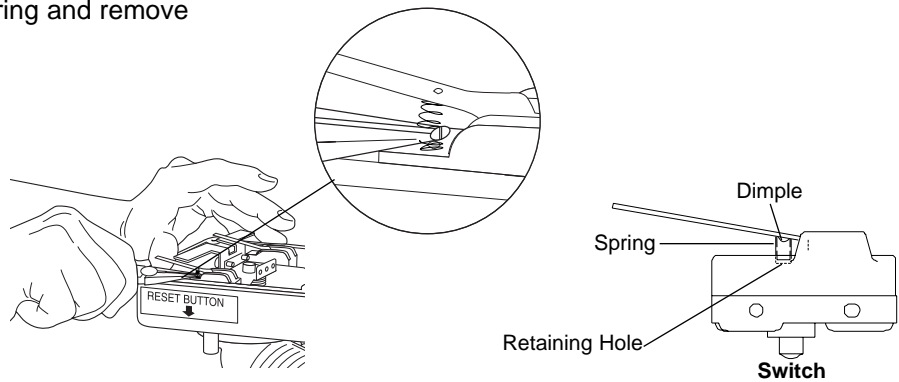

6. Grab replacement spring with pliers as shown with pliers pinching top and center of spring.

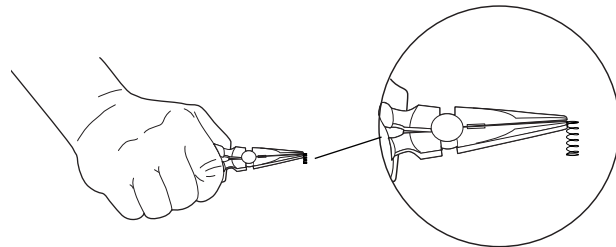

7. Place thumb under switch lever arm and push up lightly against bracket screw. **Do not bend lever.**

Insert pliers with spring under lever and rotate spring into position.

- Locate bottom of spring into retaining hole (A) of switch
- Locate top of spring into lever arm dimple (B). It is important that the spring be seated around the dimple.

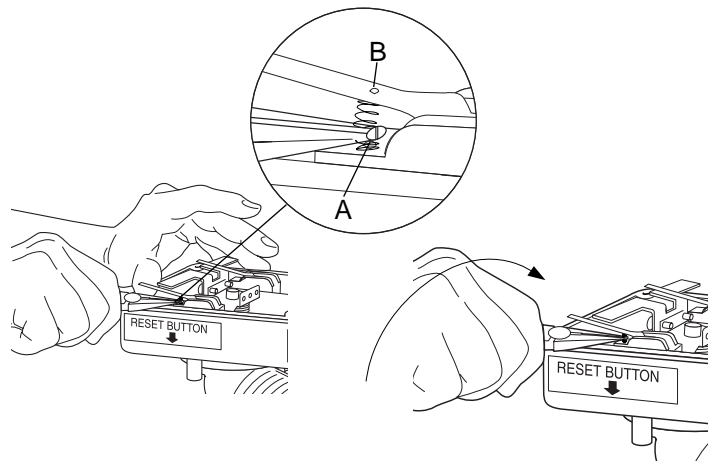

8. Test switch operation after installation of new spring.

- Gently hold down switch lever arm
- Press red reset button (switch should click)
- Allow switch lever arm to return to original position (switch should click again)

Note: If switch does not click, there could be a problem and the entire head should be replaced. Contact your local M&M distributor for a replacement.

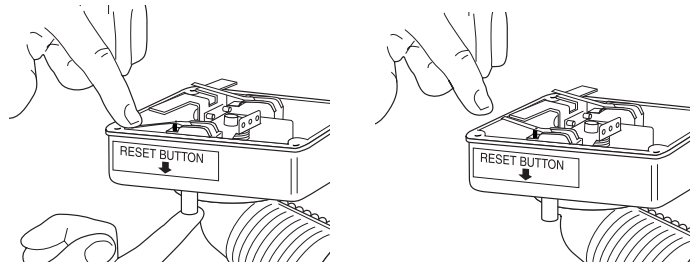

9. Replace junction box cover and turn on power to pump and burner switch circuits.

When water level is raised to normal operating level, press reset button.

Burner should turn on or activate after reset button is pressed.

Test Operation of Control as Follows:

- With boiler at normal water level and burner on, open blow-down valve. This causes the water level to drop in the float chamber of control. As the float drops, pump circuit will close first. A further drop in water level will open the cut-off circuit – stopping the burner and closing alarm circuit to sound an alarm.
- Close blow-down valve. Restore water level in boiler to correct level and repeat test two or three times under actual operating conditions to make certain control is working properly.

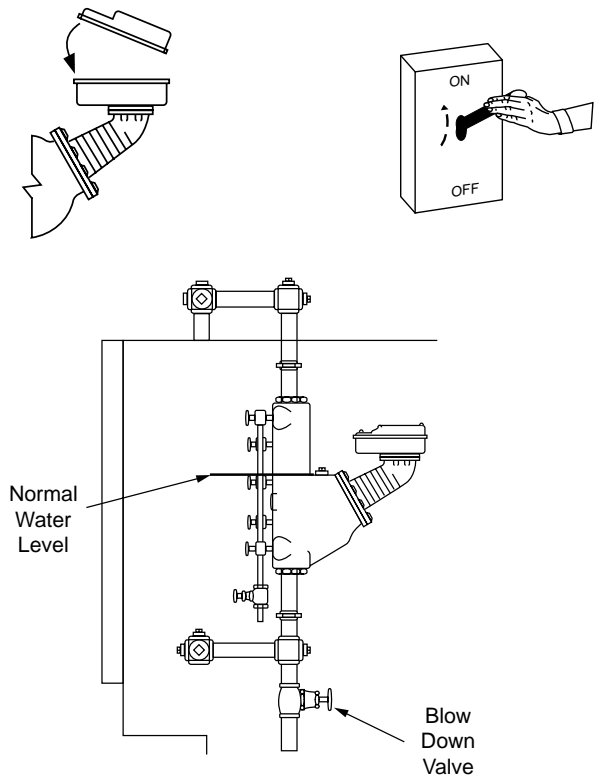

10. Fill out and attach sticker to unit next to 'Manual Reset' label.

Fill out and return response card after spring has been replaced and unit has been tested.

Notice To Installer: Reimbursement of charges will be tracked to receipt of this response card.



McDonnell & Miller



ITT Industries
Engineered for life

3500 N. Spaulding Avenue
Chicago, Illinois 60618
tel: 773 267-1600
fax: 773 267-0991
www.mcdonnellmiller.com

©1998 ITT Industries Inc.
Printed in U.S.A. 10-98