

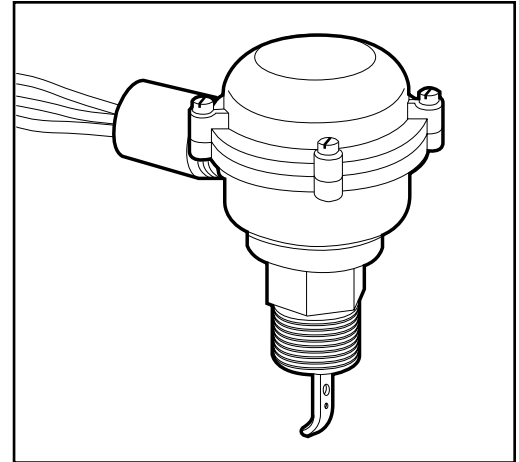

# Model FS8-WG-SL

## Flow Switch



### OPERATION

**Maximum pressure:**  
160 psi (11.3 kg/cm<sup>2</sup>)

**Temperature range:**  
32 - 225°F (0 - 107.2°C)

**Electrical Rating:**  
300W at 125V AC

**Electrical Switch Enclosure Rating:**  
NEMA 4X (enclosure with sealed leads)

### Electrical Ratings

Voltage	Motor Switch Rating (Amperes)		Pilot Duty
	Full Load	Locked Rotor	
120 VAC	7.4	44.4	125 VA at 120 or 240 VAC 50 or 60 cycles
240 VAC	3.7	22.2	

**IMPORTANT:** Rigid, galvanized metal conduit and fittings are required for water-tight and/or dust-tight installations.

	<p style="text-align: center;"><b>⚠ WARNING</b></p> <ul style="list-style-type: none"> <li>• Before using product, read and understand instructions.</li> <li>• Save these instructions for future reference.</li> <li>• All work must be performed by qualified personnel trained in the proper application, installation, and maintenance of plumbing and electrical equipment and/or systems in accordance with all applicable codes and ordinances.</li> <li>• To prevent serious burns, allow the flow switch and surrounding equipment to cool to 80°F (27°C) and allow pressure to release to 0 psi (0 bar) before servicing.</li> <li>• To prevent an electrical fire or equipment damage, electrical wiring insulation must have a rating of 167°F (75°C) if the liquid's temperature exceeds 180°F (82°C).</li> <li>• To prevent electrocution, when the electrical power is connected to the flow switch, do not touch the terminals, or the red, blue or yellow flow switch wires.</li> <li>• To prevent electrical shock, turn off the electrical power before making electrical connections.</li> </ul> <p>Failure to follow this warning could cause property damage, personal injury or death.</p>

# INSTALLATION –

## STEP 1 - Where to Install the Flow Switch

Determine where to install the flow switch based on the following requirements:

- a. A straight, uninterrupted run of pipe (no tees, valves, orifices, or flow impediments) of **at least** five pipe diameters in length must be provided on each side of the flow switch to ensure laminar flow. Some system conditions that require **more than** five pipe diameters are extreme pipe surface roughness, high viscosity flow media, and high flow velocity.
- b. The flow switch must be installed in the suction piping when spring-loaded check valves and/or other close coupled accessories in the pump discharge piping are used.
- c. The flow switch must be installed in a horizontal pipe, or a vertical pipe with the flow in an upward direction.

## STEP 2 - Sizing the Paddle

Determine the correct paddle length for your installation from the chart below.

Pipe Size		Paddle (Standard Length)		Trim to Length	
in.	(mm)	in.	(mm)	in.	(mm)
1	(25)	1	(25)	N/A	
1 1/4	(32)	2	(25)	1 1/4	(32)
1 1/2	(40)	2	(51)	1 1/2	(38)
2	(50)	2	(51)	1 5/8	(41)
2 1/2	(65)	3	(76)	2 1/4	(57)
3	(80)	3	(76)	2 5/8	(67)
4	(100)	6	(152)	3 5/8	(92)
6	(150)	6	(152)	5 5/8	(143)
8+	(200+)	6	(152)	N/A	

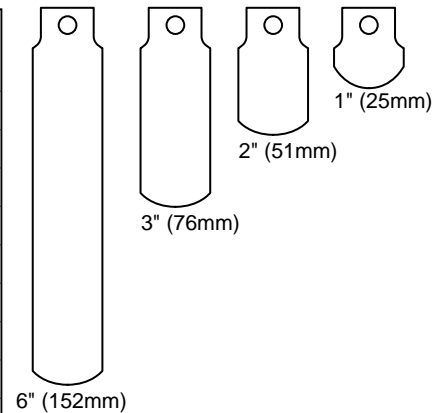

**NOTE:** All models include 4 paddles as shown.

- b. If the paddle must be trimmed, measure the paddle from the large hole (A) to the length required. Using non-serrated tin snips trim the end (B) on a curve just like the paddle was originally cut.

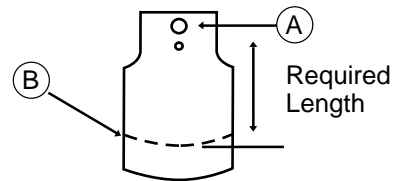

## STEP 3 - Attaching the Paddle to the Flow Switch

- a. Slide the 8-32 lockwasher (C) over the 8-32 x 1/4" (6.4mm) flathead screw (D).

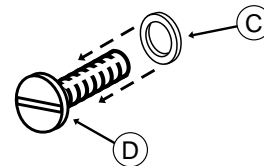

- b. Insert the flathead screw (E) through the paddle hole (A).

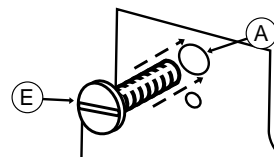

- c. Place the paddle (F) and flathead screw (E) on the opposite side of the paddle arm's curve (G) and finger tighten.

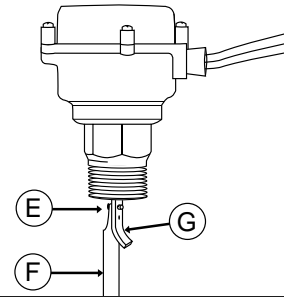

- d. Using a flathead torque screwdriver (H), tighten to a torque of 12 - 16 lb•in (1.36 - 1.81 N•m).

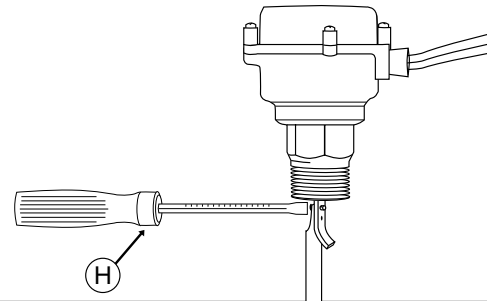

## STEP 4 - Installing the Flow Switch

*If you are installing the flow switch in a: PIPE TEE*

- a. For 1" (25mm) NPT pipe, use a 1" x 1" x 1" (25 x 25 x 25 mm) NPT pipe tee (J).

OR

- For pipe sized 1 1/4" - 6" (32 - 150mm) NPT, use a reducing tee with a 1" (25mm) NPT side outlet (K).

OR

- For pipe sized 1 1/4" - 6" (32 - 150mm) NPT, use a standard pipe tee (L) with a face or hex bushing (M) which reduces the side outlet to 1" (25mm) NPT.

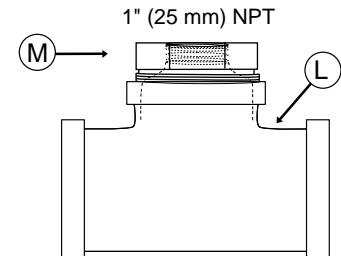
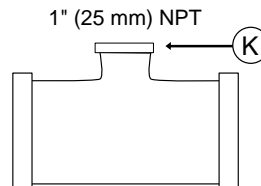
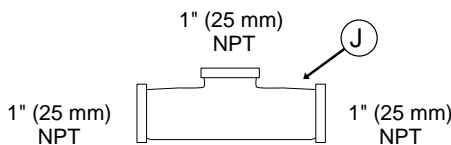

OR

*If you are installing the flow switch in a: PIPE HALF COUPLING*

- a. Install a 1" (25mm) NPT pipe half coupling (N) with a length of 1" (25mm) into the pipe.

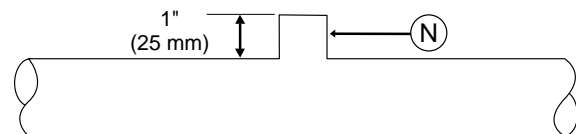

- b. Apply pipe sealing compound or Teflon® tape to the flow switch pipe threads (P).

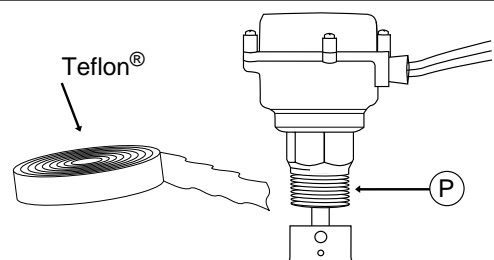

- c. Insert the flow switch (Q) into the pipe tee (L) or pipe half coupling (N), depending on your installation. Turn the flow switch (Q) two (2) or three (3) revolutions by hand.

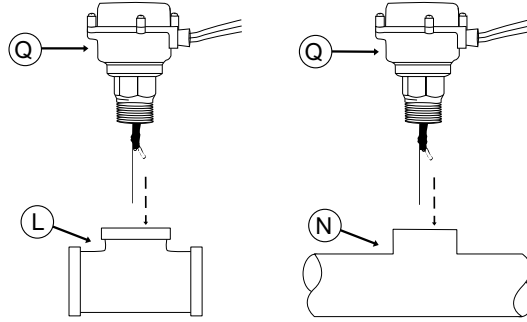

- d. Place a 1 3/8" (35mm) open end box wrench (R) on the hex (S) and tighten the flow switch (Q). The final position of the flow arrow on the side of the hex (T) must be parallel to the pipe and in the same direction as the flow.

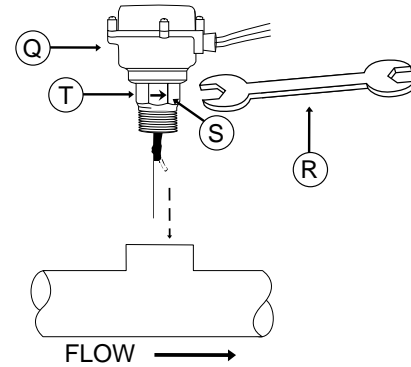

## STEP 5 - Making Electrical Connections

- a. Apply pipe sealing compound or Teflon® tape to the threads (U) of a 1/2" (15mm) NPT pipe.

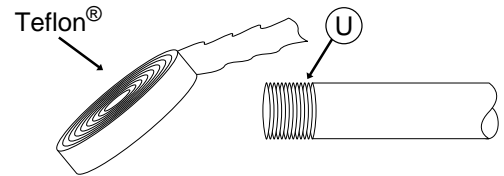

- b. Insert the three (3) wires (V) extending from the flow switch adapter (W) into the pipe (X).

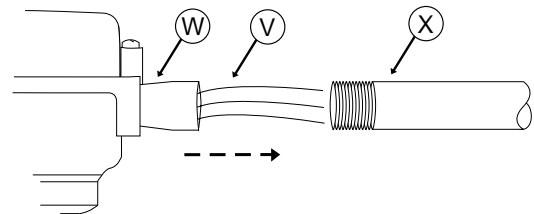

- c. Insert the pipe (X) into the adapter (W) and finger tighten.

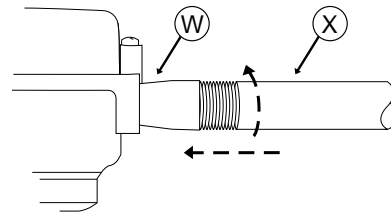

- d. Place a pipe wrench (Y) on the pipe (X) and another pipe wrench (Z) on the adapter (W). While keeping the adapter (W) stationary, tighten the pipe (X) into it.

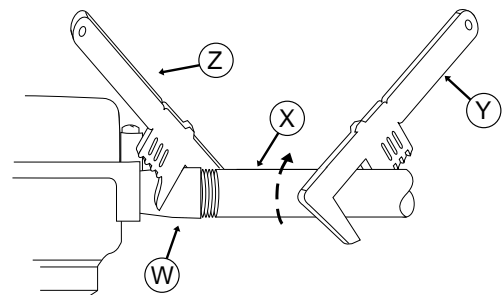

## STEP 5 - continued

- e. Verify that the paddle's full range of motion (AA) is unobstructed. Some system piping disassembly may be required.

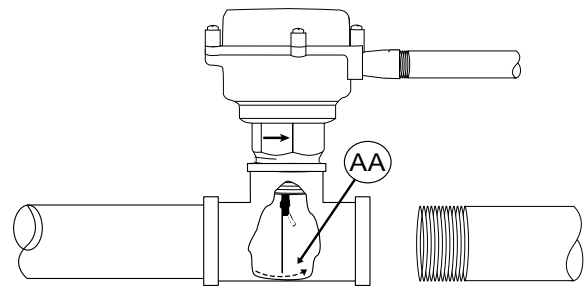

### ⚠ WARNING

- To prevent electrical shock, turn off the electrical power before making electrical connections.
  - To prevent an electrical fire or equipment damage, electrical wiring insulation must have a rating of 167°F (75°C) if the liquid's temperature exceeds 180°F (82°C).
- Failure to follow this warning could cause property damage, personal injury or death.



- f. Insert the pipe (X) into the appropriate electrical junction box (CC) and secure it.

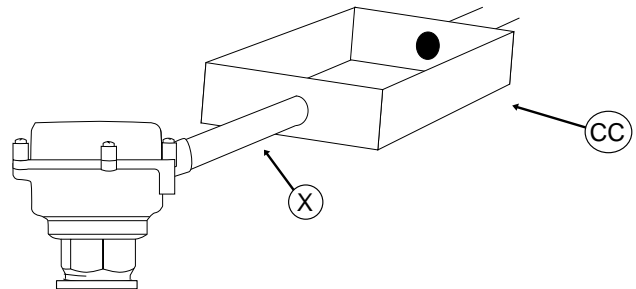

- g. Based on the mode of operation (Flow or No Flow) required for your application, complete the appropriate corresponding step (g.1 or g.2).

### g.1. For **FLOW** Mode of Operation

If the flow switch will be used to actuate a signal, alarm, or other device when *flow* occurs, connect the **yellow** flow switch wire (DD) to the appropriate wire from that device (EE). Cap with a wire nut and seal with electrical tape.

If the flow switch will also be used to actuate another device when *no flow* occurs, connect the **blue** flow switch wire (FF) to the appropriate wire from that device (GG). Otherwise, cap the **blue** wire (FF) with a wire nut and seal with electrical tape.

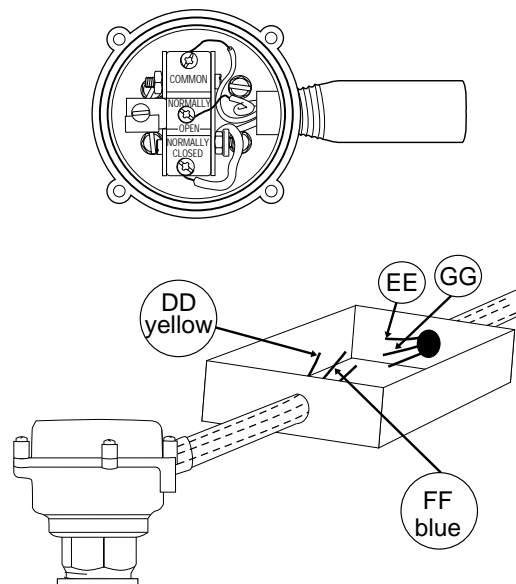

## STEP 5 - continued

### g.2. For **NO FLOW** Mode of Operation

If the flow switch will be used to actuate a signal, alarm, or other device when *no flow* occurs, connect the **blue** flow switch wire (FF) to the appropriate wire from that device (EE). Cap with a wire nut and seal with electrical tape.

If the flow switch will also be used to actuate another device when *flow* occurs, connect the **yellow** flow switch wire (DD) to the appropriate wire from that device (GG). Otherwise, cap the **yellow** wire (DD) with a wire nut and seal with electrical tape.

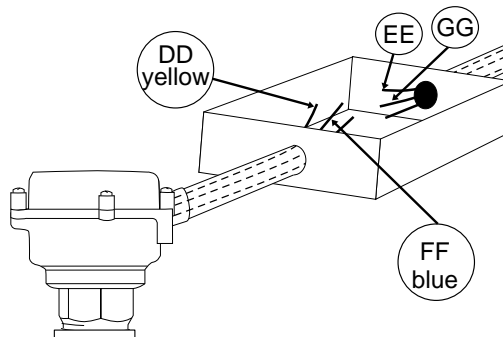

## For all installations

h. Connect the red flow switch wire (HH) to the "Hot" power supply wire (JJ). Cap with a wire nut and seal with electrical tape.

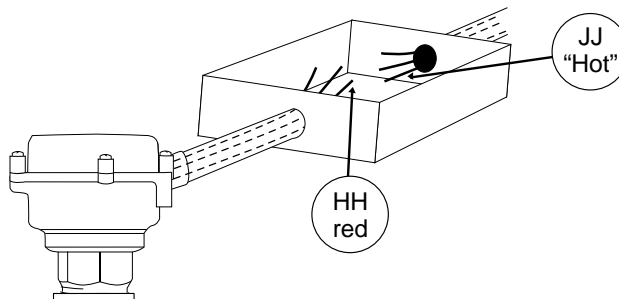

i. Cover and properly secure the electrical junction box (CC).

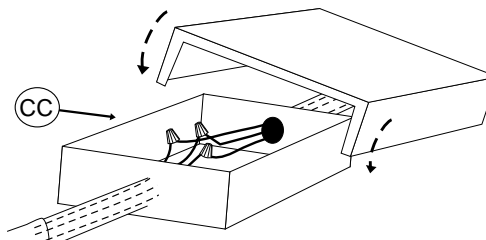

## STEP 6 - Testing

a. Turn on the electrical power to the flow switch.  
Initiate flow through the flow switch.

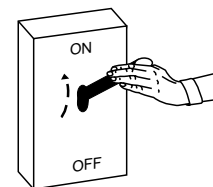

b. Observe the device being activated by the flow switch, or measure the flow rate to determine if the flow switch is activating when desired. If the flow switch isn't activating when desired, follow Step 7 to adjust the sensitivity.

## STEP 7 - Adjusting the Flow Rate (only necessary if operation above minimum flow velocities is required)

- a. Disconnect the electrical power to the flow switch.

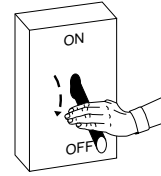

### WARNING

- To prevent electrical shock, turn off the electrical power before making electrical connections.
  - To prevent electrocution, when the electrical power is connected to the flow switch, do not touch the terminals, or the red, blue or yellow flow switch wires.
- Failure to follow this warning could cause property damage, personal injury or death.

- b. Using a flathead screwdriver (KK), unscrew the four (4) cover screws (LL) and remove the cover (MM).

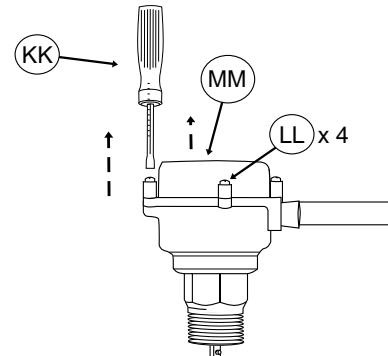

- c. Using a flathead screwdriver, turn the adjusting screw (NN) several turns clockwise.

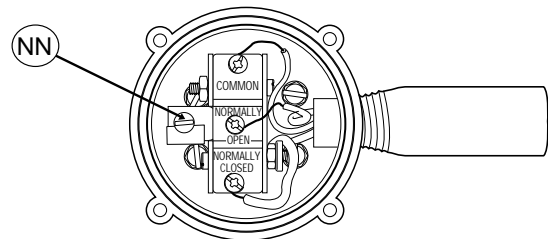

- d. Place the cover (MM) on the flow switch (S) and insert the four (4) cover screws (LL).

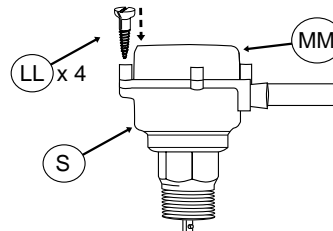

- e. Using a torque screwdriver (PP), tighten the four (4) cover screws (LL) to a torque of 10 lb.⋅in (1.13 N⋅m).

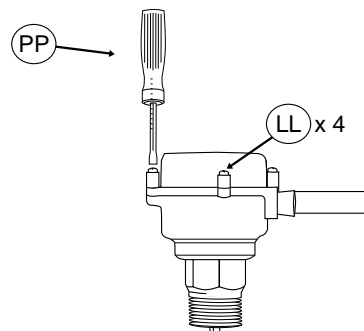

## STEP 7 - *continued*

f. Turn on the electric power to the flow switch.

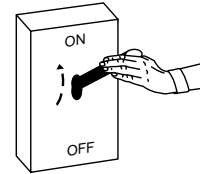

g. Observe the device being activated by the flow switch, or measure the flow rate to determine if the flow switch is activating when desired.

Refer to the Flow Rate Chart below.

If further adjustment is required, repeat Step 7.

## MAINTENANCE

### SCHEDULE:

- Replace flow switch every 5 years or 100,000 cycles, whichever comes first.

		Flow Rates							
Pipe Size NPT in. (mm)	Settings	Flow (Mode of Operation)				No Flow (Mode of Operation)			
		Flow		Velocity		Flow		Velocity	
		gpm	(lpm)	fps	(mps)	gpm	(lpm)	fps	(mps)
1 (25)	Factory or Minimum	4.9	(18.5)	1.82	(.55)	3.4	(12.9)	1.25	(.38)
	Maximum	17.6	(66.6)	6.53	(2.60)	15	(56.8)	5.56	(1.69)
1 1/4 (32)	Factory or Minimum	7.5	(28.4)	1.60	(.49)	5.3	(20.1)	1.14	(.35)
	Maximum	29	(110)	6.23	(1.9)	24.6	(93.1)	5.28	(1.61)
1 1/2 (40)	Factory or Minimum	9.4	(35.6)	1.48	(.45)	6.7	(25.4)	1.05	(.32)
	Maximum	37.8	(143)	5.95	(1.81)	32.2	(122)	5.07	(1.54)
2 (50)	Factory or Minimum	13.7	(51.8)	1.31	(.4)	9.4	(35.6)	.9	(.27)
	Maximum	56.4	(214)	5.39	(1.64)	47.4	(179)	4.53	(1.38)
2 1/2 (65)	Factory or Minimum	17.9	(67.8)	1.20	(.36)	12.1	(45.8)	.81	(.25)
	Maximum	71.3	(270)	4.78	(1.46)	59.2	(224)	3.97	(1.21)
3 (80)	Factory or Minimum	24.2	(91.6)	1.05	(.32)	16.4	(62.1)	.71	(.22)
	Maximum	89	(337)	3.87	(1.18)	72.5	(274)	3.15	(.96)
4 (100)	Factory or Minimum	35.3	(134)	.89	(.27)	27	(102)	.68	(.21)
	Maximum	118	(446)	2.89	(.91)	105	(397)	2.64	(.8)
5 (125)	Factory or Minimum	48.6	(184)	.78	(.24)	37.4	(142)	.6	(.18)
	Maximum	178	(674)	2.86	(.87)	160	(606)	2.57	(.78)
6 (150)	Factory or Minimum	60.3	(228)	.67	(.20)	46.8	(177)	.52	(.16)
	Maximum	245	(927)	2.72	(.83)	225	(852)	2.5	(.76)

McDonnell & Miller



3500 N. Spaulding Avenue  
Chicago, Illinois 60618  
tel: 773 267-1600  
fax: 773 267-0991  
www.mcdonnellmiller.com