

## Valves

### Series 27-W Liquid Level Controls

- For commercial and industrial liquid level open tank applications
- Materials of construction
  - Brass
  - Monel valve seat, EPDM disc
- Maximum pressure 35 psi (2.5 kg/cm<sup>2</sup>)
- Maximum supply pressure 100 psi (7 kg/cm<sup>2</sup>)
- Minimum liquid temperature 40°F (4.4°C)
- Maximum liquid temperature 212°F (100°C)

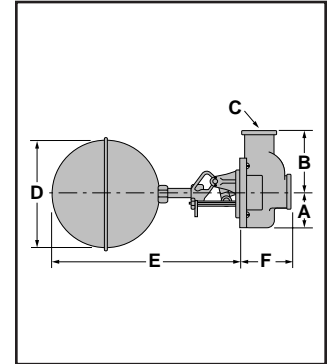

### Dimensions, in. (mm)

A	B	C NPT	D	E	F
1 <sup>9</sup> / <sub>16</sub> (40)	2 <sup>7</sup> / <sub>8</sub> (73)	3/4	5 (127)	8 <sup>5</sup> / <sub>8</sub> (219)	2 <sup>7</sup> / <sub>16</sub> (62)

### Capacities

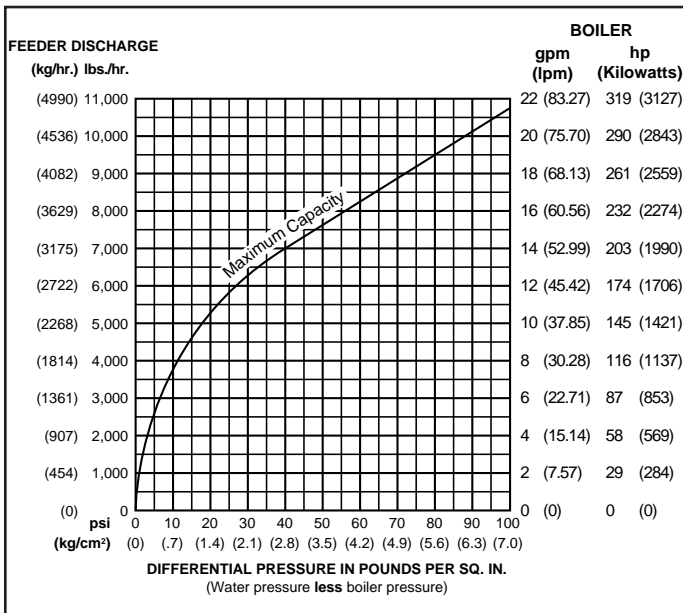

### Ordering Information

Model Number	Part Number	Description	Weight lbs. (kg)
27-W	127200	Liquid level control	5 (2.3)