

Flow Switches – Liquid

Series FS7-4W (for specified models)
Industrial Liquid Flow Switches

- For applications requiring a water-tight, dust-tight or a **NEMA 4X** rated flow switch
- 1¼" NPT
- Brass with sealed tube construction
- Single pole, double throw snap switch
- Magnetic switching mechanism eliminates need for bellows
- Sensitivity adjusting screw makes flow adjustment easy
- Paddles can be trimmed to suit application needs
- Optional features
 - Extended paddle arm
 - Stainless steel
 - BSPT threads
- Minimum temperature (fluid or ambient) -65°F (-54°C)
- Maximum temperature 300°F (149°C)
- Maximum operating pressure
 - 300 psi (21 kg/cm²)
 - 1000 psi (70 kg/cm²) – Stainless Steel models

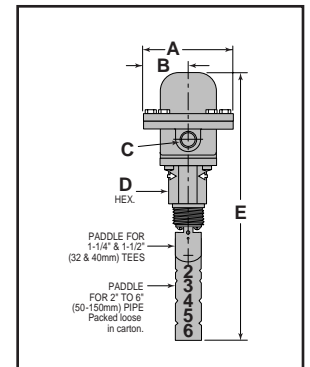
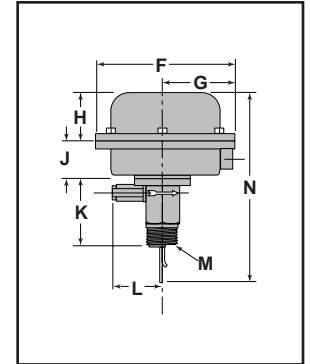

Electrical Ratings

Voltage	Motor Switch Rating (Amperes)		Pilot Duty
	Full Load	Locked Rotor	
120 VAC	7.4	44.4	125 VA at 120 or 240 VAC 50 or 60 cycles
240 VAC	3.7	22.2	

Dimensions, in. (mm)

A	B	C NPT	D	E	F	G
4 ⁵ / ₈ (117)	2 ⁵ / ₁₆ (59)	½	1 ³ / ₄ (45)	13 ³ / ₄ (350)	7 ¹ / ₄ (184)	3 ²⁵ / ₃₂ (96)
H	J	K	L	M NPT	N	
2 ⁷ / ₁₆ (62)	1 ⁵ / ₁₆ (24)	3 ⁷ / ₁₆ (87)	2 ⁵ / ₈ (67)	1 ¹ / ₄	9 ¹¹ / ₁₆ (246.6)	

FLOW SWITCHES

Flow Rates

Pipe Size NPT in.	Settings	Mode of Operation				Max. Flow Rate gpm (lpm) w/o Paddle Damage
		Flow gpm (lpm)		No Flow gpm (lpm)		
1¼	Factory or Minimum	4.8	(18.2)	3	(11.4)	47 (177.9)
	Maximum	7.7	(29.1)	5.9	(22.3)	
1½	Factory or Minimum	6.3	(23.8)	3.6	(13.6)	63 (238.5)
	Maximum	10	(37.9)	7	(26.5)	
2	Factory or Minimum	9.9	(37.5)	5.9	(22.3)	105 (397.4)
	Maximum	15.8	(59.8)	11	(41.6)	
2½	Factory or Minimum	15.3	(57.9)	9.5	(36)	149 (564)
	Maximum	23.7	(89.7)	17	(64.3)	
3	Factory or Minimum	24.4	(92.4)	15.4	(58.3)	230 (870.6)
	Maximum	35.5	(134.4)	29.2	(110.5)	
4	Factory or Minimum	33.3	(126)	21.1	(79.9)	397 (1502.7)
	Maximum	61.4	(232.4)	37.7	(142.7)	
5	Factory or Minimum	44.4	(168.1)	31	(117.3)	654 (2475.4)
	Maximum	84	(317.9)	51	(193)	
6	Factory or Minimum	56.3	(213.1)	48.7	(184.3)	900 (3406.5)
	Maximum	114.8	(434.5)	71	(270.6)	
8*	Factory or Minimum	104	(393.6)	89	(336.9)	1,500 (5677.5)
	Maximum	210	(794.9)	131	(495.8)	
10*	Factory or Minimum	184	(696.4)	157	(594.2)	2,500 (9462.5)
	Maximum	369	(1397)	231	(874.3)	
12*	Factory or Minimum	289	(1094)	247	(934.9)	3,500 (13,247.5)
	Maximum	582	(2203)	363	(1374)	
14*	Factory or Minimum	387	(1465)	323	(1223)	4,000 (15,140)
	Maximum	753	(2850)	495	(1874)	
16*	Factory or Minimum	513	(1942)	428	(1620)	5,000 (18,925)
	Maximum	998	(3777)	656	(2483)	

Values are ± 10%

* Equipped with a 6" paddle

Ordering Information

Model Number	Part Number	Description	Weight lbs. (kg)
FS7-4W	120201	FS7-4 w/NEMA 4X enclosure	12.3 (5.6)
FS7-4SW	120191	FS7-4W w/SS body	11.7 (5.3)
FS7-4WJ	120261	FS7-4W w/BSPT connections	12.3 (5.6)
FS7-4SWJ	120197	FS7-4SW w/BSPT connections	11.7 (5.3)
FS7-4WL	120301	FS7-4W w/extended paddle & paddle arm	12.7 (5.8)
FS7-4WLJ	120361	FS7-4WL w/BSPT connections	12.7 (5.8)
FS7-4WJ-E	120262	FS7-4WJ - CE conformance rated	12.7 (5.8)

See page 157 for CE Conformance information

NOTE: DO NOT USE LIQUID FLOW SWITCHES ON SYSTEMS WITH FLOW GREATER THAN 10 FEET (3M) PER SECOND.