

LPC-2000

OPERATION AND SELECTION

The LPC-2000 is a conductance-type control that will sense liquids up to 60,000 ohms resistivity. It can be used to activate a low level alarm, high level alarm, pumps to fill/drain a tank or any combination thereof. Typical applications include, but are not limited to, cooling towers, storage tanks, water fountains and condensate receivers.

The control utilizes the conductivity of a liquid to make or break circuits. Some liquids may be more resistive than the control can sense (above 60,000 ohms). The resistive and conductive properties of a liquid depend on several factors, including the amount of soluble material, temperature of the liquid, and placement of the probes. A TDS tester, which can be purchased from a supply house carrying boiler chemicals, is required to accurately measure a liquid's resistivity.

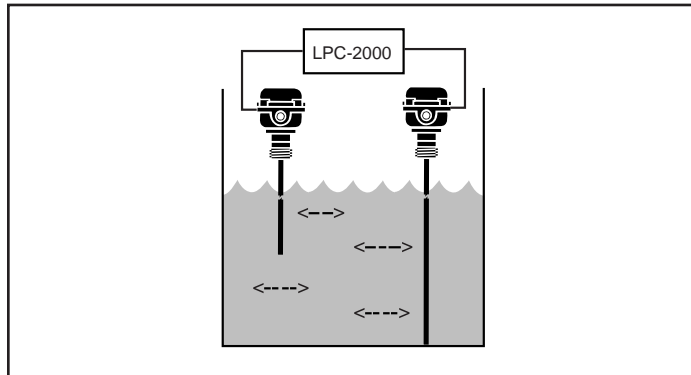

For many applications, water is the liquid being sensed. Raw or tap water usually has naturally occurring salts, chlorides and minerals that make it conductive enough to operate the control. Condensate receiver and cooling tower water are also very conductive due to evaporation. Ultrapure water (RO, deionized, demineralized, etc.) is highly resistive and is not able to conduct the current needed to operate the control.

Refer to the following charts to determine the resistivity of the liquid in an application. If it is above the 60,000 ohm rating, another type of control will be required.

Conductivity Values of Water

Liquid	Resistivity (Ohms/cm)	Conductivity (Micromhos/cm)	LPC Can Be Used
Water - Deionized	2,000,000	0.5	
Water - Distilled	450,000	2	
Water - Condensate	18,000	50	X
Water - Chlorinated	5,000	200	X
Water - Hard/Natural	5,000	200	X
Water - Sewage	5,000	200	X
Water - Salt	2,200	450	X

Converting Total Dissolved Solids to Resistivity and Conductivity

Total Dissolved Solids (ppm)	Resistivity (Ohms/cm)	Conductivity (Micromhos/cm)
0.0277	18,000,000	0.056
0.0417	12,000,000	0.084
0.0833	6,000,000	0.167
0.500	1,000,000	1.00
1.25	400,000	2.50
10.0	50,000	20.0
100	5,000	200
1,000	500	2,000
10,000	50	20,000

LPC-2000

OPERATION AND SELECTION

Each control is able to perform 3 separate functions. The following is a description of each of the functions.

- The high alarm contact (terminals 3 and 4) closes when a liquid comes in contact with the probe connected to terminal P5.
- The low alarm contact (terminals 5 and 6) closes when the liquid is no longer in contact with the probe connected to terminal P2.
- Differential control contacts (terminals 7 and 8) open or close depending on whether water is or is not in contact with the probes connected to terminals P3 and P4. Tank fill or drain is determined by the position of switch 2. There must be two probes of different lengths to do differential control with the shorter (pump hi) probe wired to P4 and the longer (pump lo) probe to P3.

The material of the tank or vessel determines if an additional probe is required for grounding. Metal tanks do not require an additional probe because the tank is the ground path needed to complete the current path. Plastic, concrete and lined metal tanks will require a ground probe for use to complete the current path. It is highly recommended that a ground probe be added on all installations. The less distance the current has to travel to complete the path the better the control operates, especially in liquids with high resistance.

The following tips can be useful when selecting a control for an application.

- An alarm point or contact should not be used to operate a valve or pump. Because the contact opens/closes whenever the liquid is/is not in contact with the probe, wave action of the liquid can cause short cycling.
- There should be a difference in the length of the probes to prevent short cycling due to wave action of the liquid.
- The alarm and pump contacts are isolated dry contact connections. They can be used in circuits of any voltage.
- Wires from the remote sensor to the control should be in their own conduit. If run in conduit with other wires, there may be interference that can affect the controls operation. The wire should be a minimum of 18ga stranded control type wire.
- Length of wires from remote sensor to control should not exceed 50 ft. Whenever feasible, the distance should be as short as possible.
- A LPC-2000 **SHOULD NOT** be used with oil, gasoline, diesel fuel, or other carbon based liquids. They are typically non-conductive and because of their flammability require the use of intrinsically safe controls.

Conductance Actuated

Series LPC-2000 General Purpose Liquid Level Controls

- Industrial and commercial level sensing and pump control of cooling towers, tanks, water fountains, condensate units, and others.
- Digital technology utilizing a micro-controller
- Field selectable control unit allows for single or multi-level sensing
- Directly switches a 1 HP motor
- 1 to 3 operating modes:
 - Low Level Alarm
 - High Level Alarm
 - Pump-On/Off
- Compact size
- Time delay feature prevents process disturbances from water level surges
- One control unit for many applications makes selection and stocking easy
- Panel mounting capability for easy installation

Specifications

Control Unit:

NEMA 1 Enclosure, UL listed
 NEMA 4X Enclosure, UL listed
 Ambient Temperature 120°F (49°C)
 Power Consumption 4 VA
 Probe Sensitivity 60,000 ohms

For sensors and probes see pages 82-85

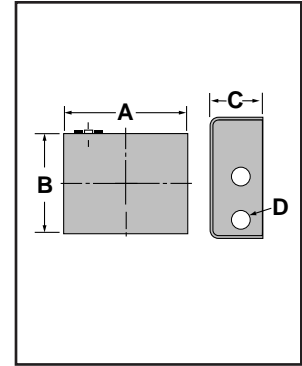

Dimensions, in. (mm)
Control Unit

Model	A	B	C	D
LPC-2000	6 ³ / ₈ (162)	5 ¹ / ₈ (130)	2 ⁹ / ₁₆ (65)	7 ⁸ / ₁₆ (22)

Electrical Ratings

Supply Voltage	Probe Voltage	Contact Ratings @ 120 VAC			
		FLA	LRA	Alarm	HP
120 VAC 50/60 Hz	12 VAC	16	96	360 VA	1
220 VAC 50/60 Hz	12 VAC				

Ordering Information

How To Order

1. Order control unit LPC-2000.
2. Select and order an appropriate remote sensor, based on the number of levels to be sensed.
3. Order the number of probes necessary (1 to 5), in the appropriate lengths, as required for your application. Sensors and probes are on page 82-85.

Control Unit

Model Number	Part Number	Description	Weight lbs. (kg)
LPC-2000	176217	Control unit	2.7 (1.2)
LPC-2000W	176270	LPC w/NEMA 4X	2.7 (1.2)
LPC-2000E	176271	LPC w/220 VAC Input	2.7 (1.2)
LPC-2000EW	176272	LPC w/NEMA 4X & 220 VAC Input	2.7 (1.2)

Conductance Actuated

Series PCH & PCL General Purpose Liquid Level Controls

- For sophisticated multi-level control in tanks, boilers and hydronic systems
- Electronic circuitry with remote conductance probe level sensing:
 - Series PCH probe sensitivity - 4,000 ohms at 120 VAC for boiler water and most common liquid
 - Series PCL probe sensitivity - 60,000 ohms at 28 VAC for commercial distilled water and solutions
- Teflon® coated probes provide protection from false signals [available on 24 - 72" (610 - 1829mm) probes]
- No blow down required
- Current limiting device provided
- Probe lengths 12 - 72" (305 - 1829mm) in 12" (2.5cm) increments
- Remote sensors accommodate 1 - 3 probes
- Control enclosures are NEMA 1 rated and remote sensors are NEMA 4X rated
- Optional features
 - Manual reset switch
 - Alternate pump switch
 - 28 Volt probe – Series PCL; 120 Volt probe – Series PCH
- Maximum ambient temperature 120°F (49°C)

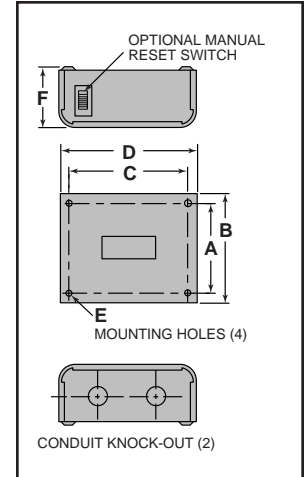

Ordering Information

Control, remote sensor and probe(s) must be ordered separately. Order Spacer S-4 when 2 or more probes greater than 36" (914mm) will be used.

Sensors and probes are on page 82-85.

Controls

Model Number	Part Number	Description	Weight lbs. (kg)
PCH-G-A-1	179120	Control; 1 level w/125V for probe	2.7 (1.2)
PCH-G-A-1K	179121	Control; 1 level w/120/240V for probe	2.7 (1.2)
PCH-G-A-2	179150	Control; 2 levels w/125V for probe	2.7 (1.2)
PCH-G-M-1	179130	PCH-G-A-1 w/manual reset	2.7 (1.2)
PCH-G-M-1K	179131	Control; 1 level w/120/240V for probe and manual reset	2.7 (1.2)
PCL-G-A-1	179100	Control; 1 levels w/28V for probe	2.7 (1.2)
PCL-G-A-2	179140	Control; 2 levels w/28V for probe	2.7 (1.2)
PCL-G-M-1	179110	PCL-G-A-1 w/manual reset	3.0 (1.4)

Electrical Ratings

Voltage	Motor Switch Rating (Amperes)		Pilot Duty
	Full Load	Locked Rotor	
120 VAC	7.4	44.4	360 VA at 120 or 240 VAC
240 VAC	3.7	22.2	

Dimensions, in. (mm)

Control Unit	A	B	C	D	E	F
1 & 2 level	4 ³ / ₁₆ (106)	5 ¹ / ₈ (130)	5 ¹ / ₂ (140)	6 ⁵ / ₈ (168)	5 ⁵ / ₃₂ (4)	2 ³ / ₄ (70)