

Series 14-B Valve Retainer Improvement

Effective May 1999, the Series 14-B ball type blow down valve includes a flat 304 stainless steel retainer. The new flat retainer replaces the copper “spider” design. In addition to being more corrosion resistant, the new design is also thicker, adding rigidity to the valve.

The diagrams below show the design change. The smaller drawings on either side are close-up pictures of the old (left) and new (right) retainer. New valves with a flat retainer are completely interchangeable with existing product.

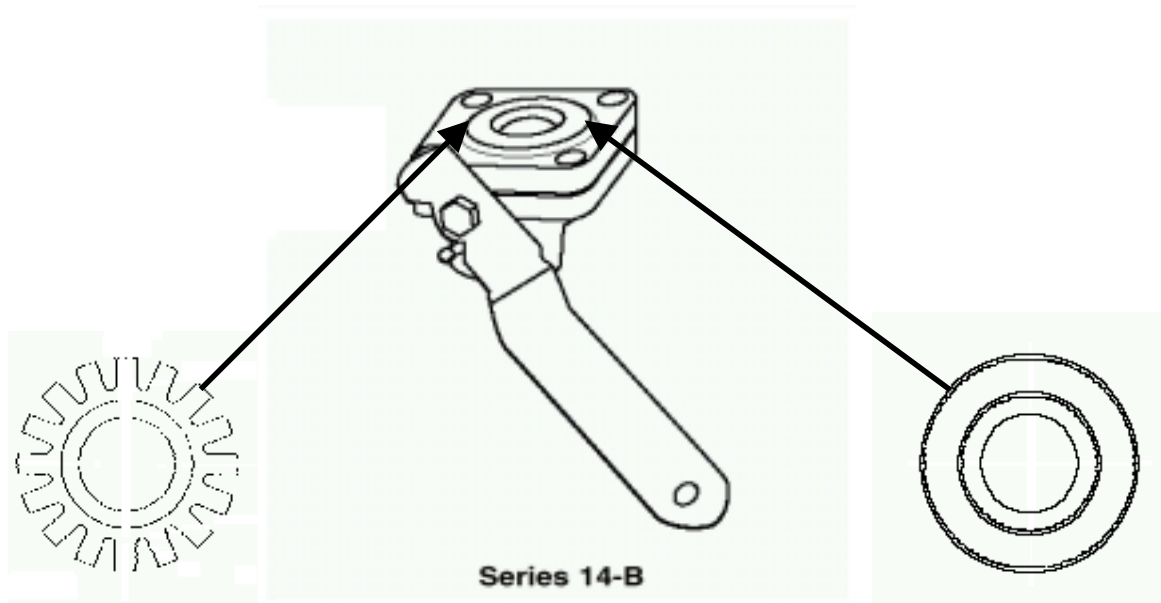

Before May 1999

After May 1999

If you have any questions please call.

Jerry McCallum
M&M Product Line Manager